

General Description

The ZM048N03D combines advanced trench MOSFET technology with a low resistance package to provide extremely low $R_{DS(ON)}$. This device is ideal for load switch and battery protection applications.

Features

- Advance high cell density Trench technology
- Low $R_{DS(ON)}$ to minimize conductive loss
- Low Gate Charge for fast switching
- Low Thermal resistance

Application

- MB/VGA Vcore
- SMPS 2nd Synchronous Rectifier
- POL application
- BLDC Motor driver

Product Summary

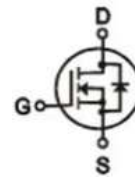

$V_{DS} = 30V$

$R_{DS(ON)} = 4.8m\Omega$

$I_D = 75A$

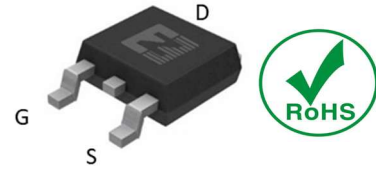

TO-252

Ordering Information:

Part NO.	ZM048N03D
Marking	ZM048N03
Packing Information	REEL TAPE
Basic ordering unit (pcs)	2500

Absolute Maximum Ratings ($T_c = 25^\circ C$)

Parameter	Symbol	Rating	Unit
Drain-Source Voltage	V_{DS}	30	V
Gate-Source Voltage	V_{GS}	± 20	V
Continuous Drain Current	$I_{D@TC=25^\circ C}$	75	A
	$I_{D@TC=75^\circ C}$	57	A
	$I_{D@TC=100^\circ C}$	47	A
Pulsed Drain Current ^①	I_{DM}	180	A
Total Power Dissipation	$P_D@TC=25^\circ C$	60	W
Total Power Dissipation	$P_D@TA=25^\circ C$	2.0	W
Operating Junction Temperature	T_J	-55 to 150	$^\circ C$
Storage Temperature	T_{STG}	-55 to 150	$^\circ C$
Single Pulse Avalanche Energy	E_{AS}	200	mJ

•Thermal resistance

Parameter	Symbol	Min.	Typ.	Max.	Unit
Thermal resistance, junction - case	R_{thJC}	-	-	2.1	$^{\circ}C/W$
Thermal resistance, junction - ambient	R_{thJA}	-	-	62.5	$^{\circ}C/W$
Soldering temperature, wavesoldering for 10s	T_{sold}	-	-	265	$^{\circ}C$

•Electronic Characteristics

Parameter	Symbol	Condition	Min.	Typ	Max.	Unit
Drain-Source Breakdown Voltage	BV_{DSS}	$V_{GS} = 0V, I_D = 250\mu A$	30			V
Gate Threshold Voltage	$V_{GS(TH)}$	$V_{GS} = V_{DS}, I_D = 250\mu A$	1.2		2.5	V
Drain-Source Leakage Current	I_{DSS}	$V_{DS} = 30V, V_{GS} = 0V$			1.0	μA
Gate- Source Leakage Current	I_{GSS}	$V_{GS} = \pm 20V, V_{DS} = 0V$			± 100	nA
Static Drain-source On Resistance	$R_{DS(ON)}$	$V_{GS} = 10V, I_D = 20A$		4.8	6.2	m Ω
		$V_{GS} = 4.5V, I_D = 10A$		6.8	9.0	m Ω
Forward Transconductance	g_{FS}	$V_{DS} = 25V, I_D = 10A$		12		S
Source-drain voltage	VSD	$I_S = 20A$			1.28	V

•Electronic Characteristics

Parameter	Symbol	Condition	Min.	Typ	Max.	Unit
Input capacitance	C_{iss}	$V_{DS} = 25V$ $f = 1MHz$	-	1500	-	pF
Output capacitance	C_{oss}		-	280	-	
Reverse transfer capacitance	C_{rss}		-	140	-	

•Gate Charge characteristics($T_a = 25^{\circ}C$)

Parameter	Symbol	Condition	Min.	Typ	Max.	Unit
Gate Resistance	R_g	$f = 1MHz$		1.7		Ω
Total gate charge	Q_g	$V_{DD} = 15V$ $I_D = 20A$ $V_{GS} = 10V$	-	16	-	nC
Gate - Source charge	Q_{gs}		-	5	-	
Gate - Drain charge	Q_{gd}		-	8	-	
Turn-ON Delay time	$t_{D(on)}$	$V_{GS} = 10V,$ $V_{DS} = 15V$		4.8		ns
Turn-ON Rise time	t_r			13		ns

Turn-Off Delay time	$t_{D(off)}$	$R_G = 3.3\Omega,$ $I_D = 15A$	28	ns
Turn-Off Fall time	t_f		8.3	ns

Note: ① Pulse Test : Pulse width $\leq 300\mu s$, Duty cycle $\leq 2\%$;

Fig.1 Power Dissipation

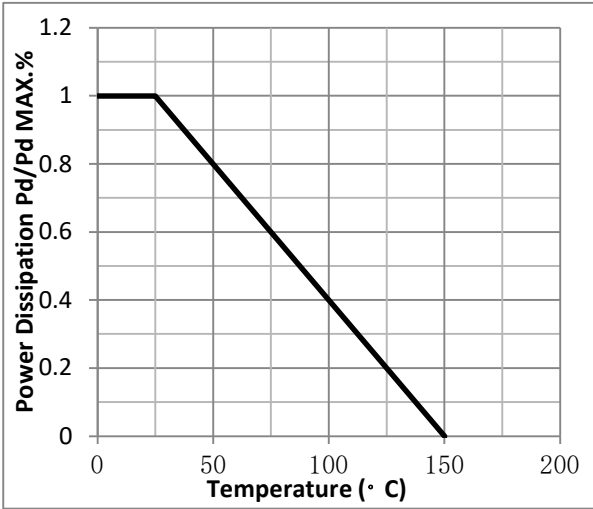

Fig.2 Typical output Characteristics

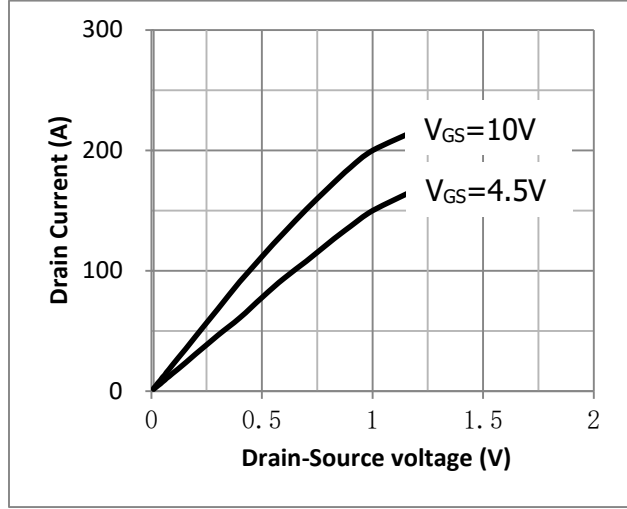

Fig.3 Threshold Voltage V.S Junction Temperature

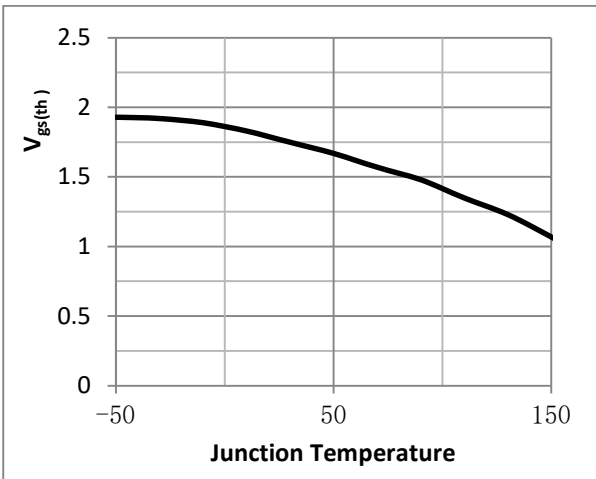

Fig.4 Resistance V.S Drain Current

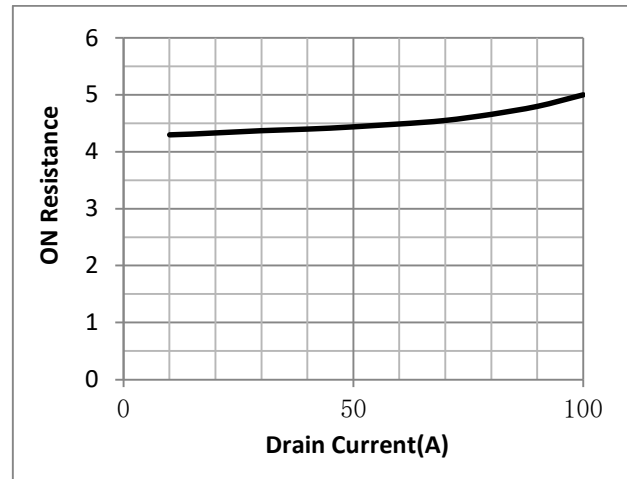

Fig.5 On-Resistance VS Gate Source Voltage

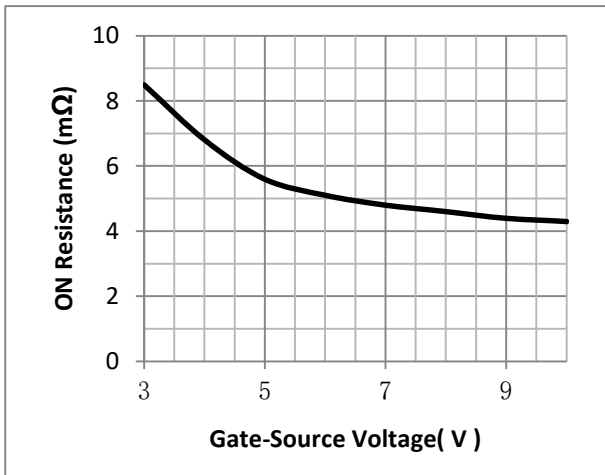

Fig.6 On-Resistance V.S Junction Temperature

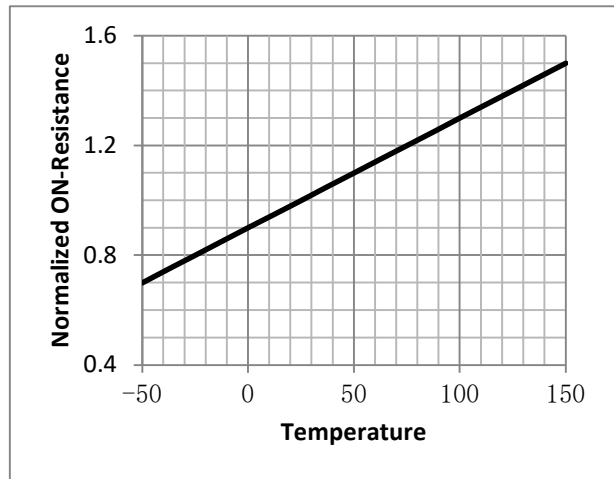

Fig.7 Gate Charge Measurement Circuit

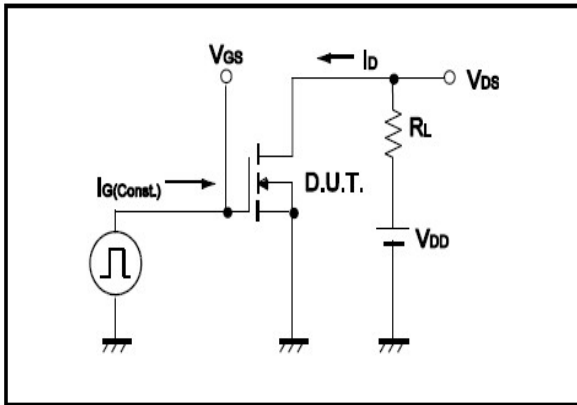

Fig.8 Gate Charge Waveform

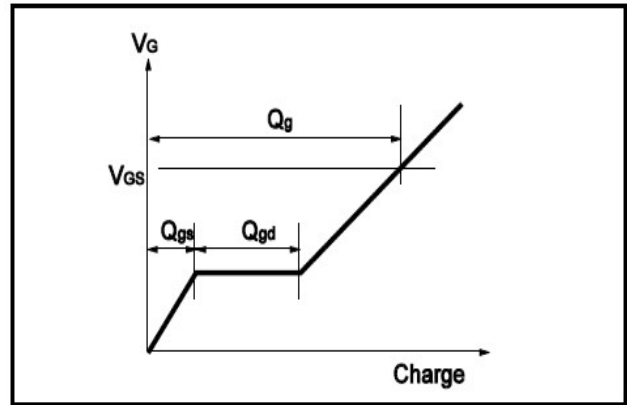

Fig.9 Switching Time Measurement Circuit

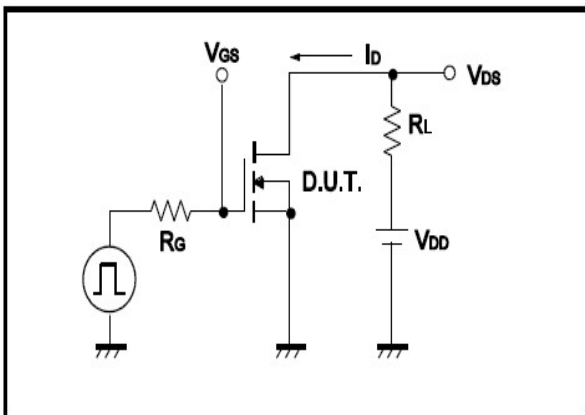

Fig.10 Switching Time Waveform

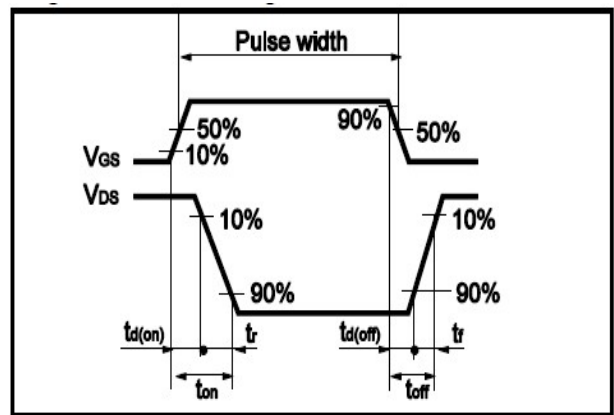



Fig.11 Avalanche Measurement Circuit

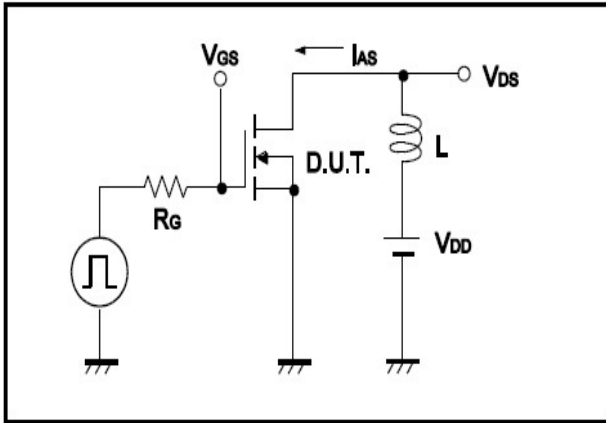
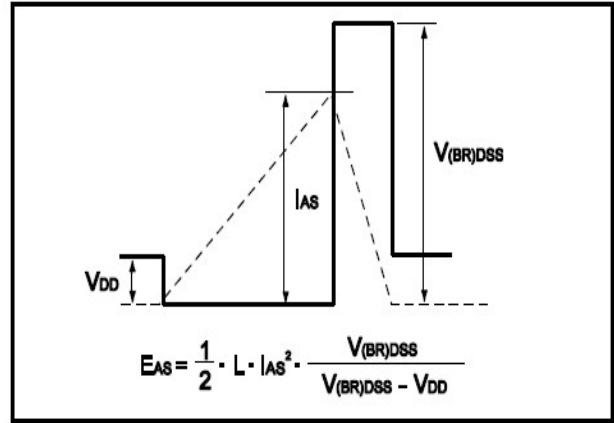
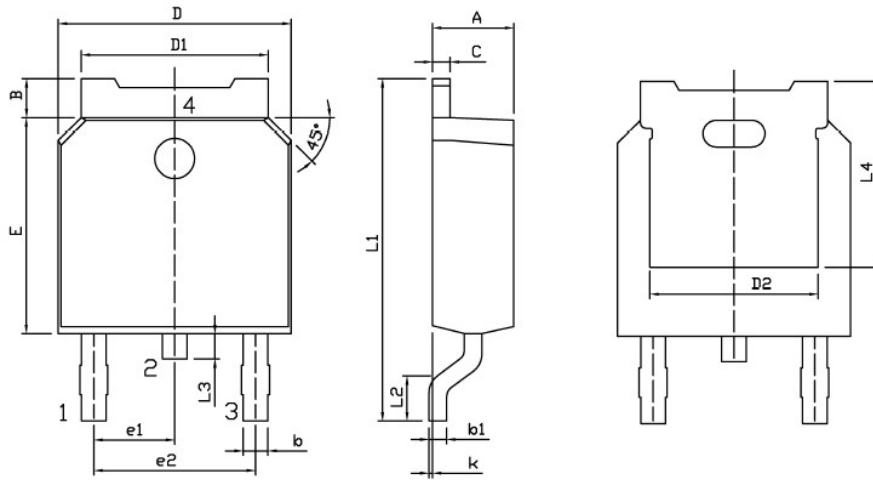

Fig.12 Avalanche Waveform





•Dimensions (TO-252)



Land Pattern
(Only for Reference)

Dimensions In Millimeters					
Symbol	MIN	MAX	Symbol	MIN	MAX
A	2.20	2.40	E	5.95	6.25
B	0.95	1.25	e1	2.24	2.34
b	0.70	0.90	e2	4.43	4.73
b1	0.45	0.55	L1	9.85	10.35
C	0.45	0.55	L2	1.70	2.00
D	6.45	6.75	L3	0.60	0.90
D1	5.10	5.50	L4	5.05	
D2	4.85		k	0.00	0.10

